



## Installation and setting instructions

### **Gatelock** Type VL21

**Publication Number - II030/0398**  
**Part Number: 002029-000002**

#### **Important**

**These instructions must remain with the product to ensure correct installation. If extra copies are required please contact Dewhurst plc and quote publication number and issue**

If you have any problems or questions, please contact our technical support desk direct on **+44 (0)20 8607 7322/7383** during office hours.

#### **Dewhurst plc**

Inverness Road Hounslow TW3 3LT United Kingdom  
tel +44 (0)20 8607 7300 fax +44 (0)20 8572 5986  
info@dewhurst.co.uk www.dewhurst.co.uk

**FIGURE 1**

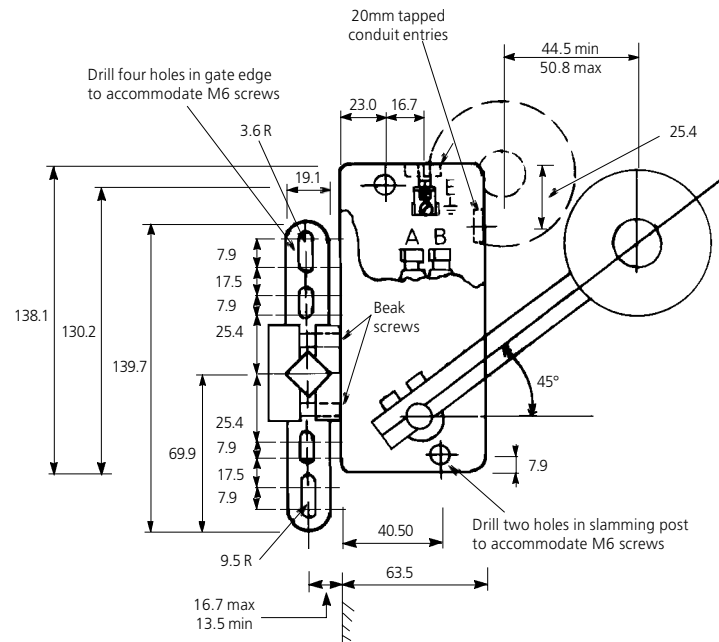

***Change of Hand***

VL21 is normally supplied for right-hand operation i.e. with door closing to right facing the lift well. For adapting to left hand operation, proceed as follows:

- i) With beak removed from lock, slacken beak screws.
- ii) Withdraw beak carrier from beak; turn vertically through 180° and insert from the opposite direction, partially tightening beak screws.
- iii) Remove operating arm from shaft.
- iv) Unscrew nut X, remove with washer and withdraw roller complete with its shaft. Turn roller and shaft through 180° and reinsert in operating arm. Replace washer and tighten nut X. See Figure 2.
- v) Place operating arm on other end of shaft, ensuring that the roller wheel is on the opposite side of the operating arm to the lock. Partially tighten nuts.
- vi) Remove lock covers and take out terminal screws and clamp plates. Replace from opposite side.
- vii) Replace lock covers.

## **APPLICATION**

The VL21 Gatelock is robustly constructed for installation on lift landings with side closing single collapsible gates or single sliding doors.

Operation is in accordance with BS5655 : Part 1 : 1986, except for Clause 7.7.3.1.1 and Appendix F.1.

For use as like-for-like replacement only, in accordance with BS5655 : Parts 11 & 12 : Clause 2.2.

## **ENVIRONMENT**

VL21 is suitable for application in all normal indoor locations. Abnormal locations involving water spraying or splashing, chemical fumes and ignitable or explosive gases or dusts, require more detailed consideration. If in doubt concerning location or installation, consult the manufacturers.

## **OPERATION**

The gatelock should be used in conjunction with a suitable retiring ramp (Dewhurst Type FR21 is suitable for this application).

When the landing door/gate is closed, the beak enters the lock and engages with an insulated cam which carries contacts that then complete a primary circuit (A). When the ramp clears the lock roller the operating arm of the gatelock falls forward allowing the locking plate to move downward, trapping the beak in position. The beak locking action is accompanied by the completion of a secondary circuit (B), but only if the primary circuit has been made.

## **MECHANICAL INSTALLATION**

The gatelock must be installed with the beak and the operating arm below the lock centre line and with the conduit entries at the top. Check that the gatelock has been assembled to suit the handing required. Cut-off unrequired shaft to ensure free action against mounting post.

The gatelock must be mounted with the beak entry face in line with the slamming post but not in front of it. Use dimensional data supplied to mark the fixing positions for the lock on the slamming post and also to mark the centre line of the beak carrier on the gate edge channel. Drill fixing holes in slamming post and secure lock with two M6, rustproof, countersunk-head screws together with spring-washers and nuts.

If the gatelock is to be fitted to a collapsible gate, mark and drill the gate edge channel with four holes to accommodate M6 screws at the spacing indicated on Figure 1, positioning them 1.6mm from the top of the slots in the beak carrier. If a sliding door is to be used, obtain from the door supplier details of his recommended method of fitting the gatelock.

Fit the gatelock and beak as appropriate and check that the beak lines up with the entry in the lock. Adjust height of the beak carrier as necessary using slotted holes and make horizontal adjustments by moving the beak along the square shank of the carrier. Tighten all fixing screws and nuts. Slacken nuts on the operating arm clamp. Move the arm along the shaft until the roller centre line coincides with the centre line of the retiring ramp. If necessary, further outward extension of the roller can be achieved by slackening nuts X and Y and positioning roller as necessary. Tighten nuts X and Y. See Figure 2.

**FIGURE 2**

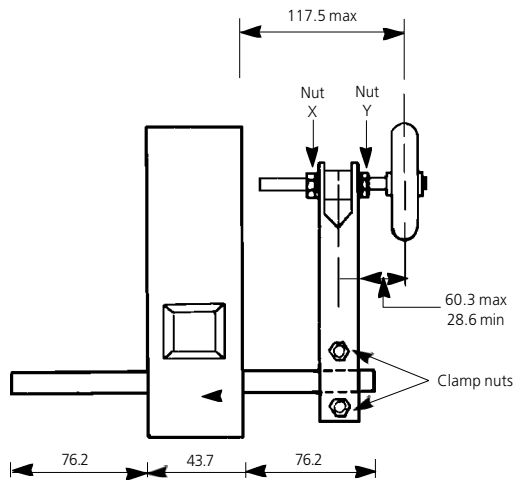

**FIGURE 3**

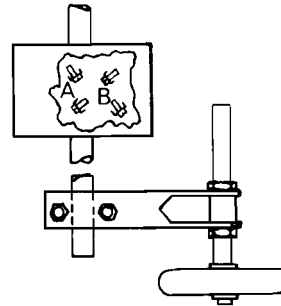

**NOTES:**

1. **Roller operating force 1kgf**
2. **No cantilever load to be applied to shaft**

Set the operating arm at 45° to the lock body, with the roller above the centre line and towards the lift well. Set the retiring ramp to move the roller a minimum of 44.5mm and a maximum of 50.8mm towards the lock body as illustrated. Tighten nuts on the clamp to compress fully the spring-washers but not more. Do not over-tighten the nuts.

If, when the operating arm is positioned on the shaft an excessive length remains beyond the arm, cut off surplus leaving between 6.3mm and 19.0mm of length.

**ELECTRICAL CONNECTIONS**

Ensure main and control supplies are isolated.

Remove front cover from the lock. Utilise one of two 20mm tapped conduit entries to bring wires into the gatelock. Ensure conduit termination is tight and secure. If flexible conduit is utilised, a separate earth wire must be installed in the conduit and must be securely connected to a suitable earth terminal in the electrical installation. Plug unused conduit entry.

Connect primary circuit using beak contact terminals A and secondary circuit using ramp contact terminals B. Connect earth wire to terminals E. See Figure 4.

Check that the cables do not impede movements of the mechanism and that the springs controlling the locking plate are correctly located.

Replace front cover and tighten securing screws.

**CONTACTS**

Both sets of contacts are self-aligning and have a self-cleaning action with positive knock-off feature.

All dimensions in mm